

# Solenoid valve(5/2 way, 5/3 way)

## 4V400 Series

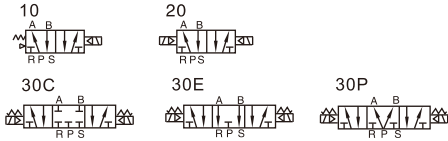

### Symbol



### Product feature

1. Pilot-oriented mode: Internal pilot or external pilot.
2. Structure in sliding column mode: good tightness and sensitive reaction.
3. Three position solenoid valves have three kinds of central function for your choice.
4. Double control solenoid valves have memory function.
5. Internal hole adopts special processing technology which has little attrition friction, low start pressure and long service life.
6. No need to add oil for lubrication.
7. It is available to form integrated valve group with the base to save installation space.
8. Affiliated manual devices are equipped to facilitate installation and debugging.
9. Several standard voltage grades are optional.

### Ordering code

4V 4 10 15 A □ G



① Model	② Code	③ Valve type	④ Port size	⑤ Voltage	⑥ Electrical entry	⑦ Thread type
4V: Solenoid valve (5/2, 5/3 way)	4: 400 Series	10: Single solenoid 5/2 way 20: Double solenoid 5/2 way 30C: Double solenoid 5/3 way closed center 30E: Double solenoid 5/3 way exhaust center 30P: Double solenoid 5/3 way pressure center	15: 1/2"	A: AC220V B: DC24V C: AC110V E: AC24V F: DC12V	Blank: Terminal I: Grommet[Note]	G: G Thread

[Note] The wire length is 0.5m. Please refer to 79 for manifold specification and the order way.

### Flow chart

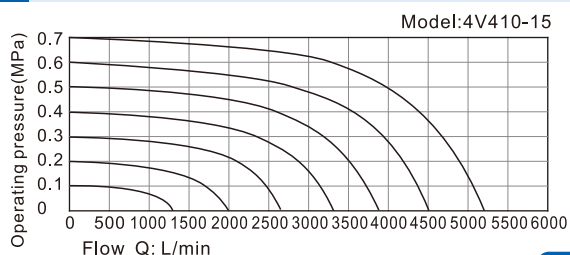

The data in flow rate chart are obtained from AirTAC lab.

### Specification

Model	4V410-15	4V420-15	4V430C-15	4V430E-15	4V430P-15
Fluid	Air(to be filtered by 40 μm filter element)				
Acting	Internal pilot or external pilot				
Port size [Note1]	In=Out=Exhaust=1/2"				
Orifice size(Cv) [Note4]	4V410-15,4V420-15:48.0mm <sup>2</sup> (Cv=2.82) 4V430C-15:40.0mm <sup>2</sup> (Cv=2.35)				
Valve type	5 port 2 position		5 port 3 position		
Operating pressure	0.15~0.8MPa(21~114psi)				
Proof pressure	1.2MPa(175psi)				
Temperature	-20~70°C				
Material of body	Aluminum alloy				
Lubrication [Note2]	Not required				
Max. frequency [Note3]	3 cycle/sec				
Weight (g)	590	720			770

[Note1] G thread is available.

[Note2] Once lubricated air is used, continue with same medium to optimise valve life span. Lubricants like ISO VG32 or equivalent are recommended.

[Note3] The maximum actuation frequency is in the no-load state.

[Note4] Equivalent orifice S and Cv are all calculated from the flow rate data.

### Coil specification

Item	specification				
Standard voltage	AC220V	AC110V	AC24V	DC24V	DC12V
Scope of voltage	AC: ± 15% DC: ± 10%				
Power consumption	4.5VA	4.5VA	5.0VA	3.0W	2.5W
Protection	IP65(DIN40050)				
Temperature classification	B Class				
Electrical entry	Terminal, Grommet				
Activating time	0.05 sec and below				

# Solenoid valve(5/2 way,5/3 way)

## 4V400 Series

### Inner structure

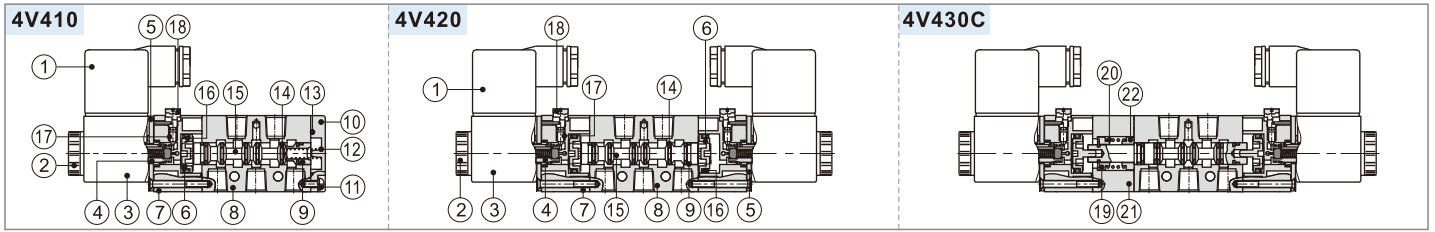

No.	Item	No.	Item	No.	Item	No.	Item	No.	Item	No.	Item	No.	Item	No.	Item	No.	Item	No.	Item	No.	Item
1	Connector	3	Coil	5	Fixed plate	7	Pilot kit	9	Wear ring	11	Fixed screw	13	Bottom cover gasket	15	Spool	17	Override spring	19	Spring holder	21	Side cover
2	Coil nut	4	Armature	6	Piston	8	Body	10	Bottom cover	12	Spool spring	14	Spool O-ring	16	Piston O-ring	18	Manual override	20	Return spring	22	Spring holder

### Dimensions

4V410(Terminal)

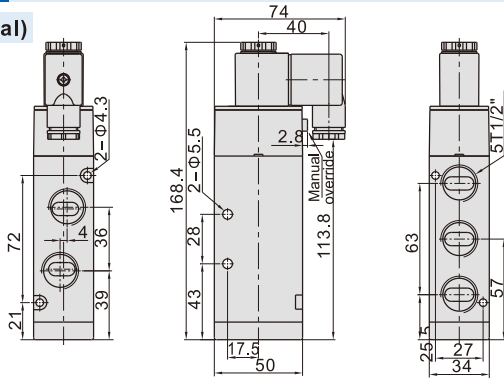

4V410(Grommet)

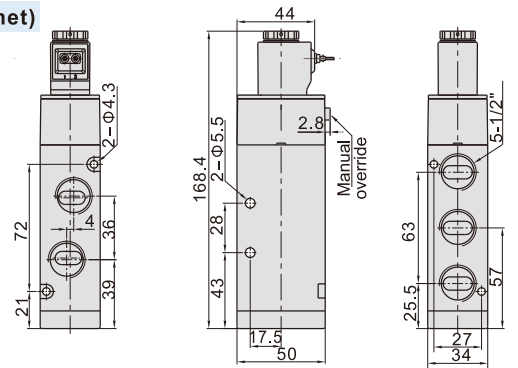

4V420(Terminal)

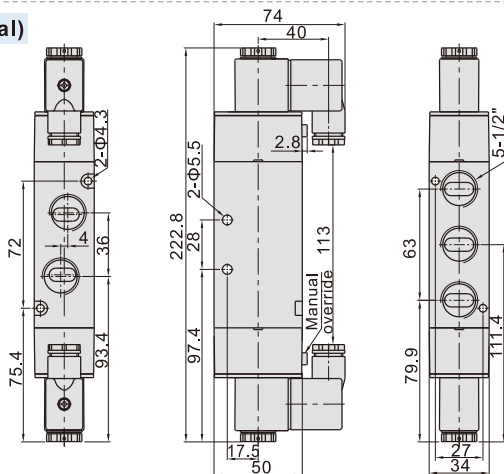

4V420(Grommet)

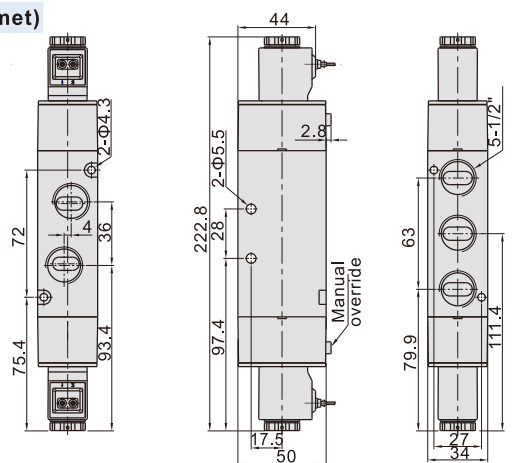

4V430(Terminal)

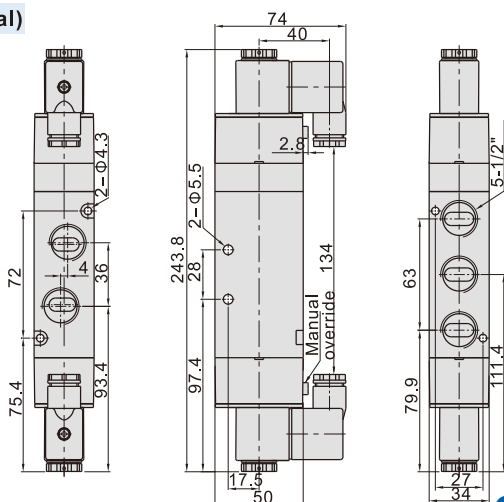

4V430(Grommet)

