

5.2 Alarm Output Graphics of ESM-3723

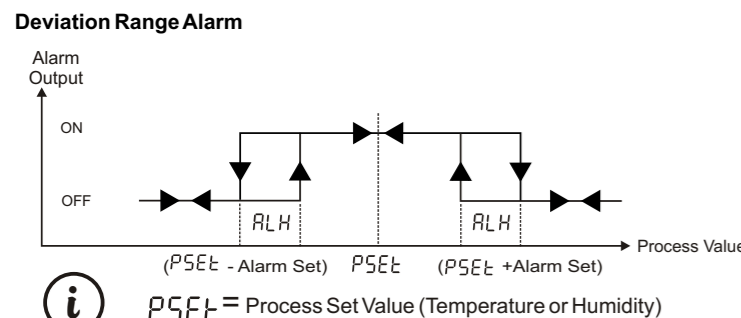
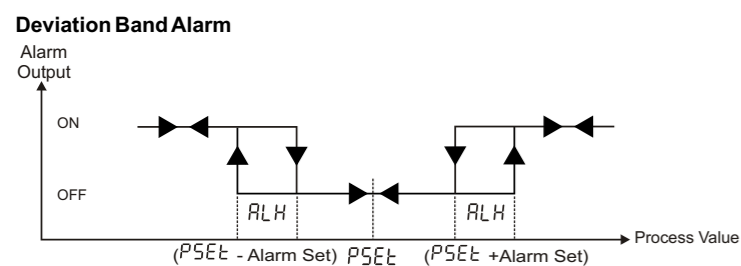
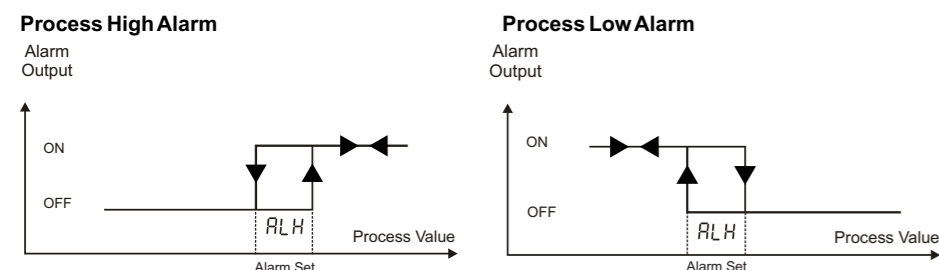

5.3 Failure Messages in ESM 3723

- Screen Blinking Temperature Sensor failure. Sensor connection is wrong or there is no sensor connection. While this message shown on this display, if buzzer function selection [b u F] is 3, 5, 7 or 8 internal buzzer starts to operate.
- Screen Blinking Humidity Sensor failure. Sensor connection is wrong or there is no sensor connection. While this message shown on this display, if buzzer function selection [b u F] is 4, 6, 7 or 8 internal buzzer starts to operate.
- In main operating screen if the upper display is blinking, it means that temperature alarm exits and alarm output is active, if buzzer function selection [b u F] is 1, 5 or 8 internal buzzer starts to operate.
- In main operating screen if the lower display is blinking, it means that humidity alarm exits and alarm output is active, if buzzer function selection [b u F] is 2, 6 or 8 internal buzzer starts to operate.

13

5.5 Entering To The Programming Mode, Changing and Saving Parameter

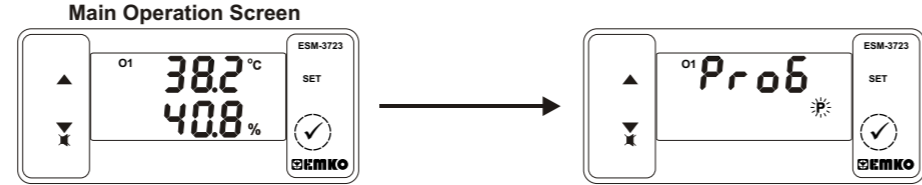

Note1: If programming mode accessing password is 0, Temperature Unit screen [C-F] is observed instead of programming screen [P r].

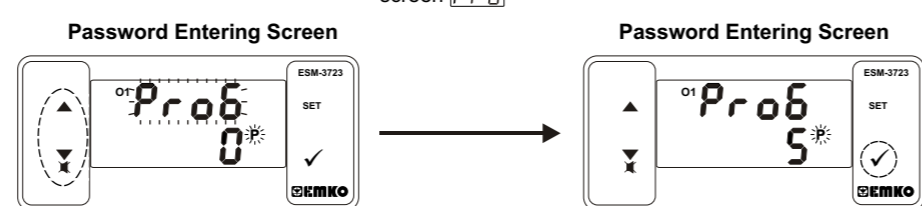

Note2: If programming mode accessing password is 0, only three parameters are accessible, and the parameter values can be changed.

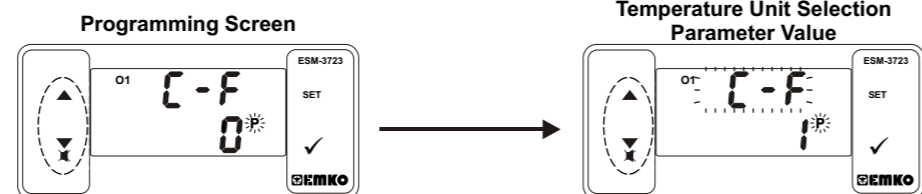

Press SET button for accessing to the parameter value. Press increment button for accessing to the next parameter, press decrement button for accessing to the previous parameter.

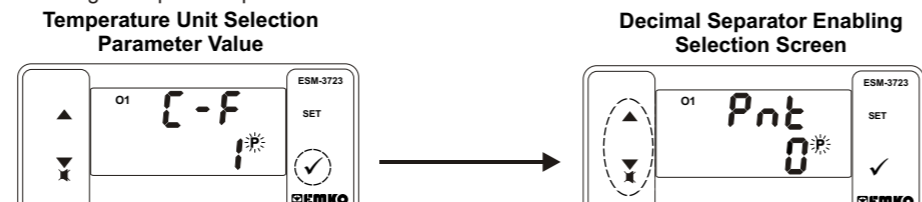

Press SET button for saving the parameter.

If no operation is performed in programming mode for 20 seconds, device turns to main operation screen automatically.

14

6. Auto Tune Metod

Auto Tune method is used for determining PID parameters used by the device.

Starting Auto Tune (Limit Cycle Tuning) Operation by the user:

- Adjust temperature control on/off or PID parameter (P=0)
- Adjust auto tune selection parameter (AT=1)
- In the main screen "Atun" and Temperature value are should alternately.

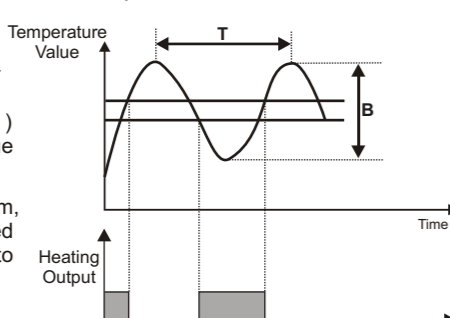

If Auto Tune operation is finished without any problem, the device saves the new PID coefficients, calculated using the previously found "T" and "B" values, to memory and continue to run. [AT] parameter is adjusted [AT] automatically.

Cancelling Auto Tune (Limit Cycle Tuning) operation:

- If sensor breaks;
- If auto tune operation can not be completed in 8 hours;
- If user adjusts [AT] parameter [AT];
- During auto tune operation if the user changes the temperature control from pid to on/off;
- If process set value is changed while auto tune operation is being performed;

Auto tune is canceled. "Atun" is not displayed. Then, without doing any changes in PID parameters, device continues to run with previous PID parameters.

7. Specifications

Device Type	: Temperature+Humidity Controller
Housing&Mounting	: 76 mm x 34.5 mm x 71 mm Plastic housing for panel Panel cut out is 71 x 29 mm.
Protection Clas	: Ip65 at front, Ip20 at rear.
Weight	: Approximately 0.2 Kg
Environmental Ratings	: Standart, indoor at an altitude of less than 2000 meters with none condensing humidity.
Storage / Operating Temperature	: -40 °C to +80 °C / -30 °C to +80 °C
Storage / Operating Humidity	: 90 % max. (None condensing)
Installation	: Fixed installation
Overvoltage Category	: II
Pollution Degree	: II, office or workplace, none conductive pollution
Operating Conditions	: Continuous
Supply Voltage and Power	: 230V~ (±15%) 50/60Hz - 1.5VA : 115V~ (±15%) 50/60Hz - 1.5VA : 24V~ (±15%) 50/60Hz - 1.5VA : 24V~ (±15%) 50/60Hz - 1.5VA : 10-30V= 1.5W
Temperature Sensor Input	: NTC, PTC, PT-100, 0/2..10V=, 0/4..20mA= or ProNem Mini PMI-P
NTC input type	: NTC (10 k @25 °C)

15

7. Specifications

PTC input type	: PTC (1000 @25 °C)
Termoresistance input type	: PT-100 IEC751 (ITS90)
Humidity input type	: 0/2..10V=, 0/4..20mA= or ProNem Mini PMI-P
Accuracy	: ± 1 % of full scale
Sensor Break Protection	: Upscale
Control Form	: PID or ON / OFF
Relay Outputs	: 5 A@250 V ~ at Resistive Load (Heating Output) : 3 A@250 V ~ at Resistive Load ((Heating , (Heating Alarm), (Humidifier , (Humidifier Alarm)) : Maximum 30mA, Maximum 15V : 8 mm Red 4 digit LED Display : 8 mm Green 4 digit LED Display : P (Green), % (Green), °C (Red), °F (Red), Humidifier Output (Red), Humidifier Alarm Output (Red) Heating Output (Red), Heating Alarm (Red)
Optional SSR Driver Output	: 83dB
Temperature Display	: 8 mm Red 4 digit LED Display
Humidity Display	: 8 mm Green 4 digit LED Display
LED Displays	: P (Green), % (Green), °C (Red), °F (Red), Humidifier Output (Red), Humidifier Alarm Output (Red) Heating Output (Red), Heating Alarm (Red)
Internal Buzzer	: 83dB
Approvals	: CE

8. Other Informations

A Power Supply Voltage	1 24V~ (±15%) 50/60Hz - 1.5VA 2 24V~ (±15%) 50/60Hz - 1.5VA 3 115V~ (±15%) 50/60Hz - 1.5VA 4 230V~ (±15%) 50/60Hz - 1.5VA 5 10 - 30 V = 1.5W
B Temperature Sensor Input	1 PT 100, IEC751(ITS90) 0°C/32°F ; 100°C/212°F 2 PTC (Not-1) 0°C/32°F ; 100°C/212°F 3 NTC (Not-1) 0°C/32°F ; 100°C/212°F 4 0/2..10Vdc Voltage Input User defined 5 0/4..20mA Current Input User defined 6 ProNem Mini PMI-P -20°C/-4°F ; 80°C/176°F
C Humidity Sensor Input	1 0% - 100% 2 0% - 100% 3 0% - 100% 4 0% - 100%
E Heating Output	1 Relay Output (5 A@250 V ~, at Resistive Load 1NC , 1 NO) 2 SSR Drive Output (Maximum 30mA, Maximum 15V)
F Humidifier Output	01 Relay Output (3A@250 V ~, at Resistive Load , 1 NO)
HI Heating Alarm Output	01 Relay Output (3A@250 V ~, at Resistive Load , 1 NO)
U Humidifier Alarm Output	1 Relay Output (3A@250 V ~, at Resistive Load , 1 NO)
V Temp.Sensor which is given with ESM-3723	0 None 1 PTC-MEL40.K1.5 (PTC Air Probe 1.5 m silicon cable) 2 PTCs-MEL30.K1.5.1/8 (PTC Liquid Probe with 1.5 m silicon cable) 3 NTC-MEL20.K1.5 (NTC Probe thermoplastic moulded with 1.5m cable for cooling application) 4 NTC-MEL50.K1.5 (NTC Probe stainless steel housing with 1.5m cable for cooling application) 5 ProNem Mini PMI-P (2.5m cable for Temperature and Humidity application) 6 Customer

All order information of ESM-3723 Temperature+Humidity Controller are given on the table at above. User may form appropriate device configuration from information and codes that at the table and convert it to the ordering codes. Firstly, supply voltage then other specifications must be determined. Please fill the order code blanks according to your needs. Please contact us, if your needs are out of the Note-1: If input type is selected PTC or NTC (BC= 2, 3). Temperature sensor is given with the device. For this reason, if input type is selected as PTC, sensor type (V= 0, 1 or 2) or if input type is selected as NTC, sensor type (V= 0, 3 or 4) must be declared in ordering information.

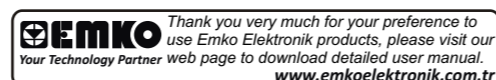

16

EMKO

ESM-3723 77x35 DIN Size Temperature+Humidity



ESM-3723 77 x 35 DIN Size Digital Temperature+Humidity Controller

- 4 Digits for Temperature Display
- 4 Digits for Humidity Display
- Temperature Sensor Input NTC, PTC, PT-100, 0/2..10V, 0/4..20mA or ProNem Mini PMI-P (Must be determined in order.)
- Humidity Sensor Input 0/2..10V, 0/4..20mA or ProNem Mini PMI-P (Must be determined in order.)
- 4 Output Heating Control Output Heating Alarm Output Humidification Control Output Humidification Alarm Output Relay or SSR Outputs (Must be determined in order.)
- Selectable Temperature Control (PID or ON / OFF)
- Auto-Tune PID
- Set value boundaries
- Alarm parameteres
- Adjustable internal buzzer according to the alarm situations
- Password protection for programming mode,
- Having CE mark according to European Norms

Instruction Manual. ENG ESM-3723 01 V03 02/15

1. Preface

ESM-3723 series Temperature + Humidity control devices, are designed for the control of industrial processes. PID or On / Off control form under the control of the process is a device that can respond to your special needs.

1.1 Environmental Ratings

- Operating Temperature : 0 to 50 °C
- Max. Operating Humidity : 90% Rh (non-condensing)
- Altitude : Up to 2000 m.
- Forbidden Conditions: Corrosive atmosphere Explosive atmosphere Home applications (The unit is only for industrial applications)

1.2. General Specifications

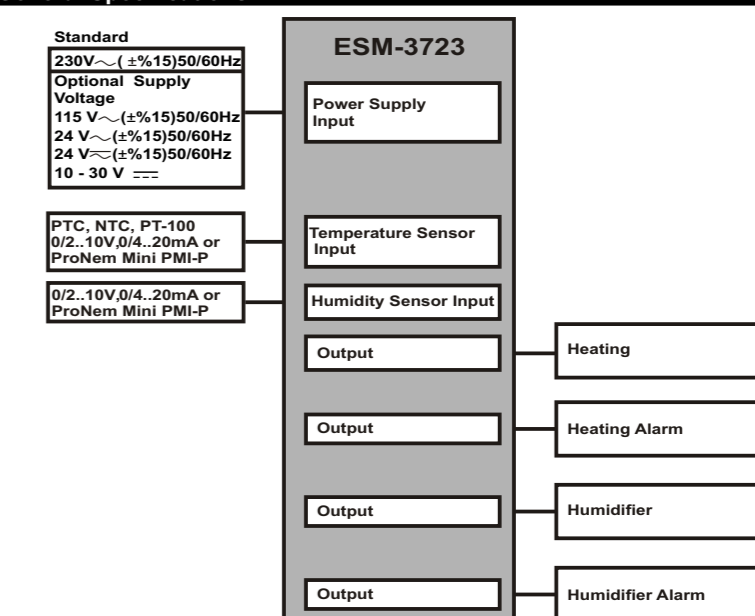

2

2. General Description

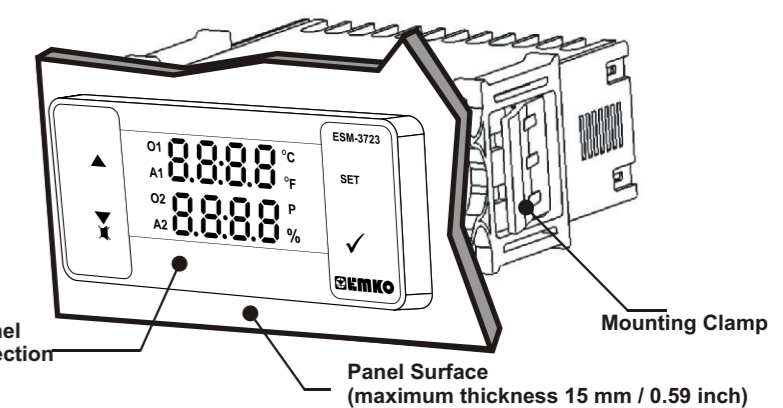

2.1 Front View and Dimensions of ESM-3723 Temperature Controller

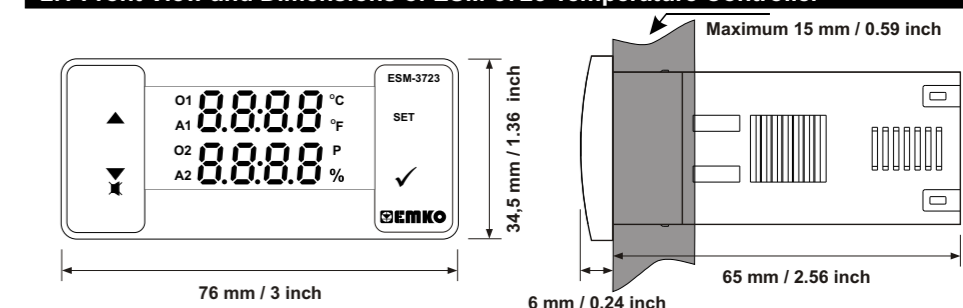

2.2 Panel Cut-Out

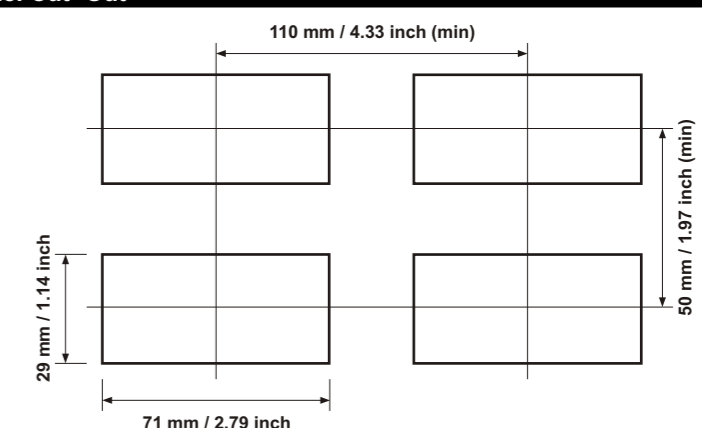

3

1.3 Installation

A visual inspection of this product for possible damage occurred during shipment is recommended before installation. It is your responsibility to ensure that qualified mechanical and electrical technicians install this product.

If there is danger of serious accident resulting from a failure or defect in this unit, power off the system and separate the electrical connection of the device from the system.

The unit is normally supplied without a power supply switch or a fuse. Use power switch and fuse as required.

Be sure to use the rated power supply voltage to protect the unit against damage and to prevent failure. Keep the power off until all of the wiring is completed so that electric shock and trouble with the unit can be prevented.

Never attempt to disassemble, modify or repair this unit. Tampering with the unit may result in malfunction, electric shock or fire.

Do not use the unit in combustible or explosive gaseous atmospheres.

During putting equipment in hole on the metal panel while mechanical installation some metal burrs can cause injury on hands, you must be careful.

Montage of the product on a system must be done with it's fixing clamps. Do not do the montage of the device with inappropriate fixing clamp. Be sure that device will not fall while doing the montage.

It is your responsibility if this equipment is used in a manner not specified in this instruction manual.

1.4 Warranty

EMKO Elektronik warrants that the equipment delivered is free from defects in material and workmanship. This warranty is provided for a period of two years. The warranty period starts from the delivery date. This warranty is in force if duty and responsibilities which are determined in warranty document and instruction manual performs by the customer completely.

1.5 Maintenance

Repairs should only be performed by trained and specialized personnel. Cut power to the device before accessing internal parts.

Do not clean the case with hydrocarbon-based solvents (Petrol, Trichlorethylene etc.). Use of these solvents can reduce the mechanical reliability of the device. Use a cloth dampened in ethyl alcohol or water to clean the external plastic case.

1.6 Manufacturer Company

Manufacturer Information:
Emko Elektronik Sanayi ve Ticaret A.Ş.
Demirtaş Organize Sanayi Bölgesi Karanfil Sk. No:6 16369 BURSA/TURKEY
Phone : +90 224 261 1900
Fax : +90 224 261 1912
Repair and maintenance service information:
Emko Elektronik Sanayi ve Ticaret A.Ş.
Demirtaş Organize Sanayi Bölgesi Karanfil Sk. No:6 16369 BURSA/TURKEY
Phone : +90 224 261 1900
Fax : +90 224 261 1912

4

2.3 Panel Mounting and Removing

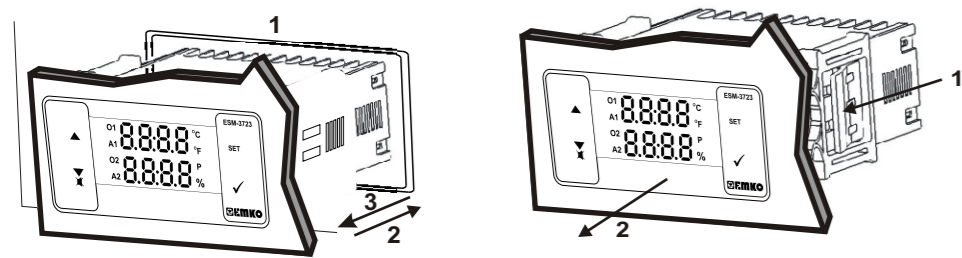

1-Before mounting the device in your panel, make sure that the cut-out is of the right size.
2-Insert the device through the cut-out. If the mounting clamps are on the unit, put out them before inserting the unit to the panel.
3- Insert the mounting clamps to the fixing sockets that located left and right sides of device and make the unit completely immobile within the panel.

1-Pull mounting clamps from left and right fixing sockets.
2-Pull the unit through the front side of the panel

Before starting to remove the unit from panel, power off the unit and the related system.

3. Electrical Wiring Diagram

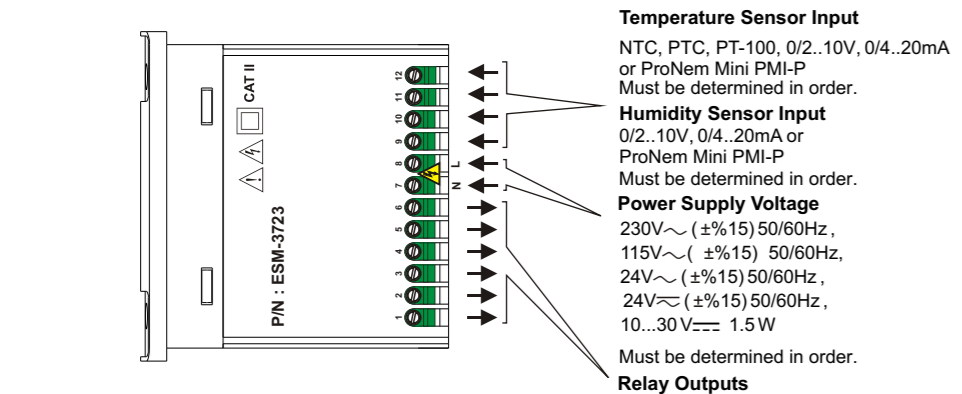

Temperature Sensor Input
NTC, PTC, PT-100, 0/2, 10V, 0/4, 20mA or ProNem Mini PMI-P
Must be determined in order.

Humidity Sensor Input
0/2, 10V, 0/4, 20mA or ProNem Mini PMI-P
Must be determined in order.

Power Supply Voltage
230V~ (±15%) 50/60Hz,
115V~ (±15%) 50/60Hz,
24V~ (±15%) 50/60Hz,
24V~ (±15%) 50/60Hz,
10...30V= 1.5W
Must be determined in order.

Relay Outputs

3.1 Supply Voltage Input Connection of the Device

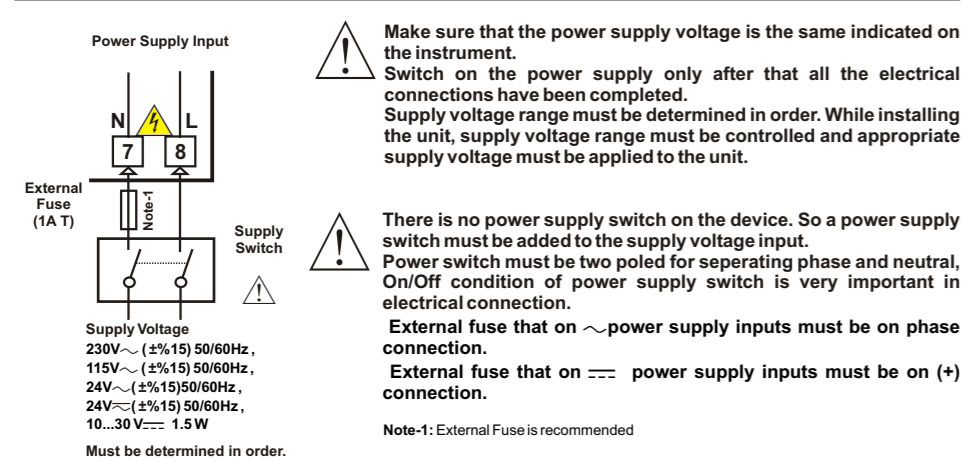

Make sure that the power supply voltage is the same indicated on the instrument.
Switch on the power supply only after that all the electrical connections have been completed.
Supply voltage range must be determined in order. While installing the unit, supply voltage range must be controlled and appropriate supply voltage must be applied to the unit.

There is no power supply switch on the device. So a power supply switch must be added to the supply voltage input.
Power switch must be two poled for separating phase and neutral, On/Off condition of power supply switch is very important in electrical connection.
External fuse that on ~ power supply inputs must be on phase connection.
External fuse that on = power supply inputs must be on (+) connection.

Note-1: External Fuse is recommended

4. Front Panel Definition and Accessing to the Menus

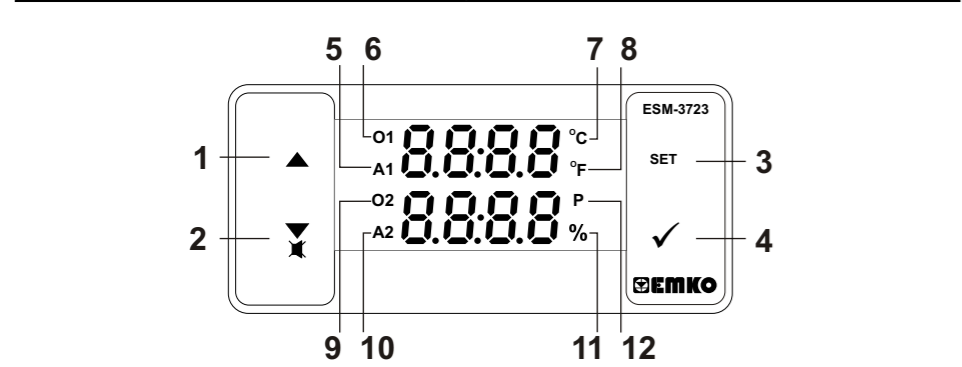

BUTTON DEFINITIONS

1. **Increment Button** :
** In main operation screen, press this button to change display temperature and humidity sensor value.

2. **Decrement, Silencing Buzzer Button** :
** It is used to decrease the value in the Temperature and Humidity Set screens and Programming mode.
** It is used to silence the buzzer.

3. **Set Button** :
** In the main operation screen; if this button pressed for the first time, Temperature set value will be displayed. Value can be changed using increment and decrement buttons. When Enter button is pressed again, value is saved and Humidity set value will be displayed next. Value can be changed using increment and decrement buttons. When Enter button pressed again, value is saved and returns back to main operating screen.

4. **Enter Button** :
** To access the programming screen; in the main operation screen, press and hold this button for 5 seconds.
** It is used to save value in the Set screens (Temperature or Humidity) and programming screen.

LED DEFINITIONS

5. **A1 led** :
** It is active when Temperature alarm statuses.

6. **O1 Led** :
** This led indicates that heating output is active.

7. **Celcius led** :
** Indicates that device is in °C mode.

8. **Fahrenheit led** :
** Indicates that device is in °F mode.

9. **O2 Led** :
** This led indicates that Humidifier output is active.

10. **A2 Led** :
** This led indicates that Humidifier Alarm is active.

11. **Precent Sign led** :
** Indicates that device is in Humidity Set screen or Humidifier output is active.

12. **Program led** :
** Indicates that device is in programming mode.

3.2 Device Label and Connection Diagram

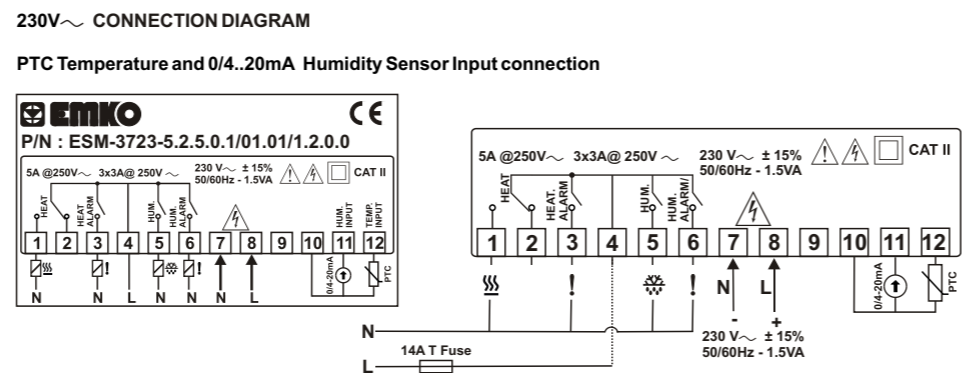

ProNem Mini PMI-P Temperature and Humidity Sensor Input Connection

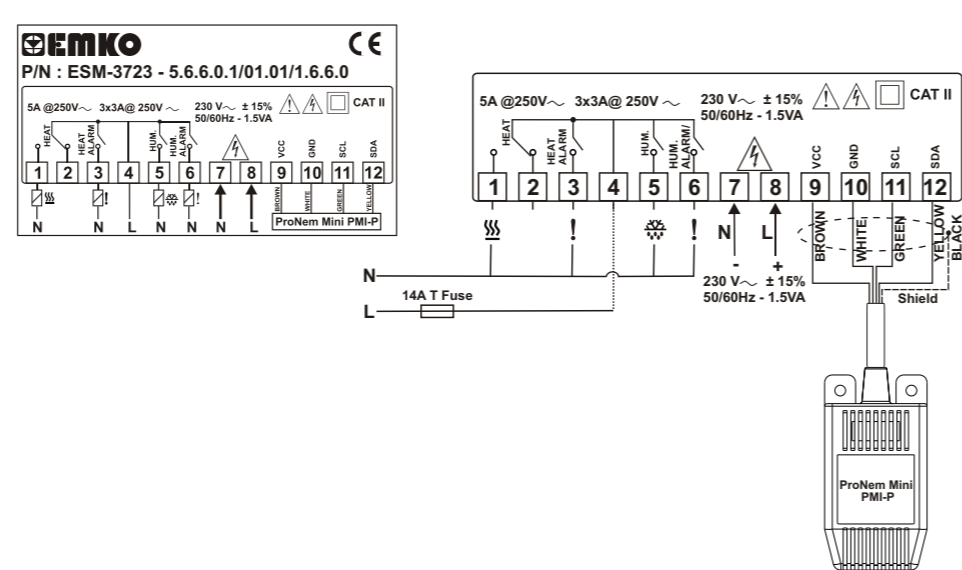

Note : Shield (Black) pin must be connected to number 10 (GND) of the terminal block.

5. Changing and Saving Temperature and Humidity Set Value

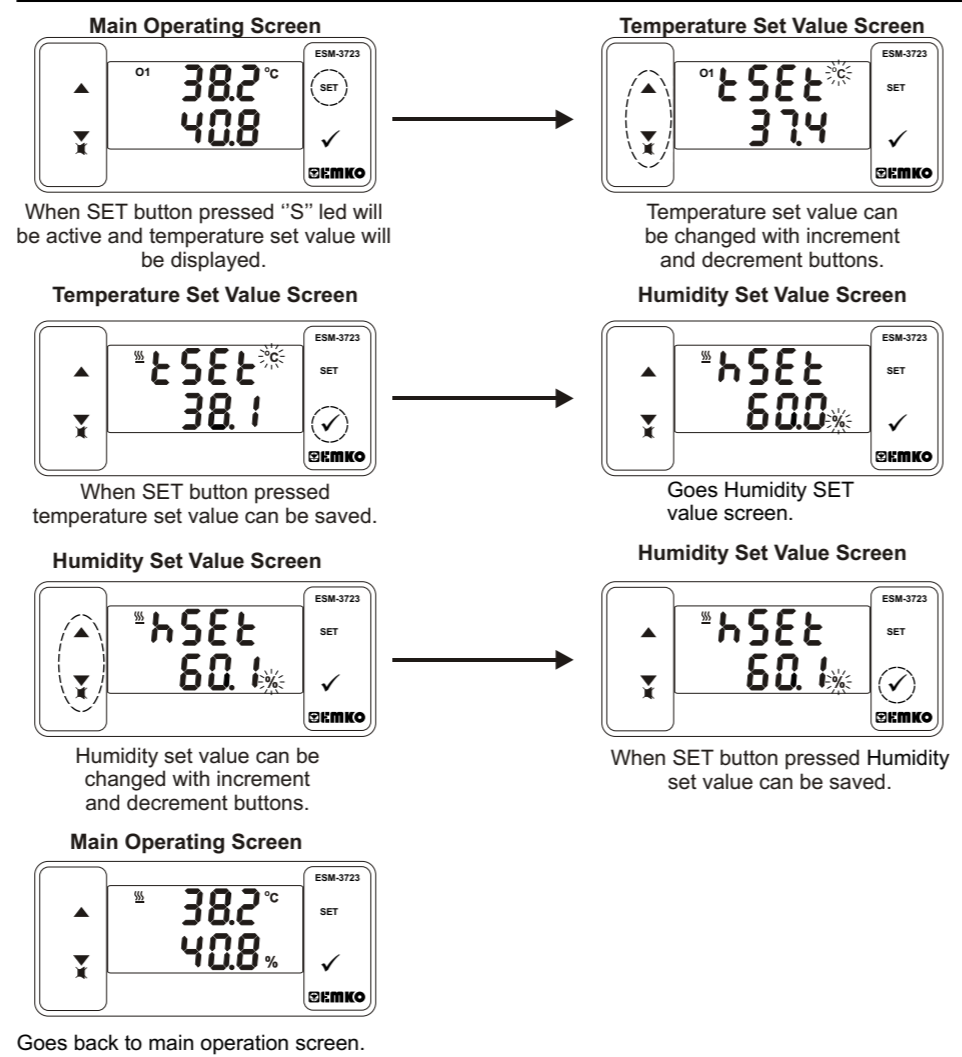

Temperature set value parameter (Default =50 °C)
Temperature set value, can be programmed between minimum temperature set value $\underline{E5UL}$ and maximum temperature set value $\underline{E5UH}$.

Nem Set Parametresi (Default = 60%)
Humidity set value, can be programmed between minimum Humidity set value $\underline{h5UL}$ and maximum temperature set value $\underline{h5UH}$.

If no operation is performed in Humidity set value changing mode and temperature set value changing mode for 20 seconds, device turns to main operation screen automatically.

5.1 Programming Mode Parameter List

C-F Temperature Unit Selection Parameter (Default = 0)
0 °C selected.
1 °F selected.

Pnt Decimal Separator Enabling Parameter (Default=0)
0 None.
1 Only Temperature parameters with decimal separator.
2 Only Humidity parameters with decimal separator.
3 Only Temperature and Humidity parameters with decimal separator.

Note : When value of $\underline{C-F}$ or \underline{Pnt} parameters are changed, the values of $\underline{E5FE}$, $\underline{E5RE}$, $\underline{h5RL}$, $\underline{h5UL}$, $\underline{h5SE}$, $\underline{h5SL}$, $\underline{h5UL}$, $\underline{h5UH}$, $\underline{h5FE}$, $\underline{h5RE}$, $\underline{h5RL}$, $\underline{h5UL}$ and $\underline{h5UH}$ parameters should be changed accordingly.

Note : $\underline{E5SL}$, $\underline{E5PL}$ and $\underline{E5OL}$ parameters are shown, if the Temperature sensor analogue input type (0/2...10V or 0/4...20mA) is selected.

E5SL Temperature Sensor Scale Selection Parameter (Default = 0)
Analogue (Temperature) input range is determined with this parameter.
0 0...10V (1) veya 0...20mA (2)
1 2...10V (1) veya 4...20mA (2)

E5OL Temperature Sensor Scale Low Limit Parameter : (Default = 0)
It can be adjusted from -1999 to ($\underline{E5OL} + 1$). At this value analogue input becomes; If $\underline{E5SL} = 0$, according to the device type 0V (1) or 0mA (2). If $\underline{E5SL} = 1$, according to the device type 2V (1) or 4mA (2).

E5PL Temperature Sensor Scale High Limit Parameter : (Default = 100)
It can be adjusted from ($\underline{E5OL} + 1$) to 9999. At this value analogue input becomes; According to the device type 10V (1) or 20mA (2).

Note : $\underline{E5OL}$, $\underline{E5PL}$ parameters are shown, if the Temperature sensor analogue input type is selected.

P-o Temperature Control Selection Parameter On/Off or PID (Default = 0)
0 On - Off selected.
1 PID selected.

Note: If this parameter is select 0, PID parameters (\underline{RtUN} , \underline{P} , \underline{I} , \underline{D}) will be not observed. If this parameter select 1, $\underline{E5ST}$ parameter will be not observed.

RtUN Auto Tune (Limit Cycle Tuning) Selection Parameter (Default = 0)
0 Device does not do(Limit cycle Tuning) operation.
1 Device does operation.

P PID - Proportional Control Parameter (Default =50)
This parameter value can be adjusted form 0 to 100.

I PID - Integral Parameter (Default = 1000)
This parameter value can be adjusted form 0 to 3600.

D PID - Derivative Parameter (Default = 250)
This parameter value can be adjusted form 0 to 3600.

t PID - Period Time Parameter (Default = 1)
This parameter value can be adjusted form 1 to 50 second.

(1) It is valid, if the device type 0/2...10V = Temperature Sensor Input.
(2) It is valid, if the device type 0/4...20mA = Temperature Sensor Input.

E5ST Hysteresis Parameter for Temperature (Default = 0.1 °C)
From 1 to 10°C for NTC, PTC, PT-100 (0°C, 100°C)
From 1 to 18°F for NTC, PTC, PT-100 (32°F, 212°F)
From 0.1 to 10.0°C for NTC, PTC, PT-100 (0.0°C, 100.0°C)
From 0.1 to 18.0°F for NTC, PTC, PT-100 (32.0°F, 212.0°F)
From 1 to 10°C for ProNem Mini PMI-P (-20°C, 80°C), From 1 to 18°F for ProNem Mini PMI-P (-4°F, 176°F), From 0.1 to 10.0°C for ProNem Mini PMI-P (-20.0°C, 80.0°C)
From 0.1 to 18.0°F for ProNem Mini PMI-P (-4.0°F, 176.0°F).

In ON/OFF control algorithm, temperature value is tried to keep equal to set value by opening or closing the last control element. ON/OFF controlled system, temperature value oscillates continuously. Temperature value's oscillation period or amplitude around set value changes according to controlled system. For reducing oscillation period of temperature value, a threshold zone is formed below or around set value and this zone is named hysteresis.

E5UL Minimum Temperature Set Value Parameter (Default = 10.0°C)
Temperature set value can not be lower than this value. This parameter value can be adjusted from minimum value of device scale to maximum temperature set value parameter $\underline{E5UH}$.

E5UH Maximum Temperature Set Value Parameter (Default = 40.0 °C)
Temperature set value can not be greater than this value. This parameter value can be adjusted from minimum temperature set value parameter $\underline{E5UL}$ to maximum value of the device scale.

E5FE Temperature Sensor Offset Parameter (Default = 0)
From -10 to 10°C, NTC, PTC, PT-100 (0°C, 100°C)
From -18 to 18°F, NTC, PTC, PT-100 (32°F, 212°F)
From -10.0 to 10.0°C, NTC, PTC, PT-100 (0.0°C, 100.0°C)
From -18.0 to 18.0°F, NTC, PTC, PT-100 (32.0°F, 212.0°F)
From -10 to 10°C, ProNem Mini PMI-P (-20°C, 80°C), From -18 to 18°F, ProNem Mini PMI-P (-4°F, 176°F), From -10.0 to 10.0°C, ProNem Mini PMI-P (-20.0°C, 80.0°C), From -18.0 to 18.0°F, ProNem Mini PMI-P (-4.0°F, 176.0°F)

h5SL Humidity Sensor Scale Selection Parameter (Default = 0)
Humidity input range is determined with this parameter.
0 0...10V (1) or 0...20mA (2)
1 2...10V (1) or 4...20mA (2)

Note : $\underline{h5SL}$ parameter ProNem Mini PMI-P type device are not observed.

h5ST Hysteresis Parameter for Humidity (Default = 1)
From 1 to 10 for Humidity Sensor (0%RH, 100%RH)
From 0.1to 10.0 for Humidity Sensor (0.0%RH, 100.0%RH)

In ON/OFF control algorithm, Humidity value is tried to keep equal to set value by opening or closing the last control element. ON/OFF controlled system, temperature value oscillates continuously. Temperature value's oscillation period or amplitude around set value changes according to controlled system. For reducing oscillation period of temperature value, a threshold zone is formed below or around set value and this zone is named hysteresis.

(1) It is valid, if the device type 0/2...10V = Humidity Sensor Input.
(2) It is valid, if the device type 0/4...20mA = Humidity Sensor Input.

h5UL Minimum Humidity Set Value Parameter (Default = Minimum Value of Device Scale)
Humidity set value can not be lower than this value. This parameter value can be adjusted from minimum value of device scale to maximum Humidity set value parameter $\underline{h5UH}$.

h5UH Maximum Humidity Set Value Parameter (Default = Maximum Value of Device Scale)
Humidity set value can not be greater than this value. This parameter value can be adjusted from minimum humidity set value parameter $\underline{h5UL}$ to maximum value of the device scale.

h5FE Humidity Sensor Offset Parameter (Default = 0.0)
From -10 to 10%RH for Humidity Sensor (0%RH-100%RH)
From -10.0 to 10.0%RH for Humidity Sensor (0.0%RH-100.0%RH)

E5AL Temperature Alarm Function Selection Parameter (Default = 0)
0 Temperature Alarm is inactive.
1 Process High alarm selected.
2 Process Low alarm selected.
3 Deviation Band alarm selected.
4 Deviation Range alarm selected.

Note : If this parameter is select 0, Temperature Alarm parameters $\underline{E5AL}$, $\underline{E5RL}$, $\underline{E5UL}$, $\underline{E5UH}$, $\underline{E5AL}$ and $\underline{E5AD}$ will be not observed.

E5SE Temperature Alarm Set Parameter (Default = 50.0 °C)
This parameter value can be programmed between temperature minimum alarm set $\underline{E5UL}$ parameter and temperature alarm set maximum $\underline{E5UH}$ parameter.

E5SL Temperature Alarm Hysteresis Parameter (Default = 0)
This parameter value can be adjusted form 0 to %50 of the device scale.

E5RL Alarm Set Minimum Parameter (Default = Minimum Value of Device Scale)
if temperature alarm is active, this parameter value can be adjusted from minimum value of device scale to temperature alarm set maximum parameter value, $\underline{E5UH}$.

E5UL Alarm Set Maximum Parameter (Default = Maximum Value of Device Scale)
if temperature alarm is active, this parameter value can be adjusted from temperature alarm set value parameter $\underline{E5UL}$ to maximum value of the device scale.

E5AD Temperature Alarm On Delay Time Parameter (Default = 0)
Temperature Alarm On Delay Time can be defined with this parameter. It can be adjusted from 0 to 99 minutes.

E5AP Temperature Alarm Delay After Power On Parameter (Default = 0)
When power is first applied to the device, this time delay must be expired for activation of temperature alarm. It can be adjusted from 0 to 99 minutes.

h5AL Humidity Alarm Function Selection Parameter (Default = 0)
0 Humidity Alarm is inactive.
1 Process High alarm selected.
2 Process Low alarm selected.
3 Deviation Band alarm selected.
4 Deviation Range alarm selected.

Note : If this parameter is select 0, Humidity Alarm parameters $\underline{h5AL}$, $\underline{h5RL}$, $\underline{h5UL}$, $\underline{h5UH}$, $\underline{h5AL}$ and $\underline{h5AD}$ will be not observed.

h5AS Humidity Alarm Set Parameter (Default = 60)
This parameter value can be programmed between humidity minimum alarm set $\underline{h5UL}$ parameter and humidity alarm set maximum $\underline{h5UH}$ parameter.

h5SL Humidity Alarm Hysteresis Parameter (Default = 0)
This parameter value can be adjusted form 0 to %50 of the device scale.

h5RL Humidity Alarm Set Minimum Parameter (Default = Minimum Value of Device Scale)
if humidity alarm is active, this parameter value can be adjusted from minimum value of device scale to humidity alarm set maximum parameter value, $\underline{h5UH}$.

h5UL Humidity Alarm Set Maximum Parameter (Default = Maximum Value of Device Scale)
if humidity alarm is active, this parameter value can be adjusted from humidity alarm set minimum parameter $\underline{h5UL}$ to maximum value of the device scale.

h5AD Humidity Alarm On Delay Time Parameter (Default = 0)
Humidity Alarm On Delay Time can be defined with this parameter. It can be adjusted from 0 to 99 minutes.

h5AP Humidity Alarm Delay After Power On Parameter (Default = 0)
When power is first applied to the device, this time delay must be expired for activation of Humidity alarm. It can be adjusted from 0 to 99 minutes.

b5F Buzzer Function Selection Parameter (Default = 0)
0 Buzzer is inactive.
1 Buzzer is active during temperature alarm
2 Buzzer is active during humidity alarm
3 Buzzer is active during Temperature sensor failures.
4 Buzzer is active during Humidity sensor failures.
5 Buzzer is active during Temperature sensor failures or temperature alarm.
6 Buzzer is active during Humidity sensor failures or Humidity alarm.
7 Buzzer is active during Temperature sensor failures or Humidity sensor failures
8 Buzzer is active during Temperature sensor failures or Humidity sensor failures or temperature alarm or humidity alarm.

bon Buzzer Active Time (Default = ---)
If buzzer function selection parameter value $\underline{b5F}$ = 0, this parameter is not observed. Buzzer active time can be define with this parameter. It can be adjusted from 1 to 99 minutes. When this parameter is 1, if decrement button is pressed, --- is observed. In this condition buzzer is active till buzzer silence button is pressed.

Prt Button Protection Parameter (Default = 0)
0 There is no protection.
1 Temperature set value can not be changed.
2 Humidity set value can not be changed.
3 Temperature set value and Humidity set value can not be changed

PR5 Programming Mode Accessing Password (Default = 0)
It is used for accessing to programming mode. It can be adjusted from 0 to 9999. If it is 0, password is not entered for accessing to the parameters. When the password screen is not set as "12", If the user enters "12" in password screen $\underline{E5SE}$ and $\underline{h5SE}$ parameters are accessed and they can be changed.