

Up to PL e of EN ISO 13849-1 PNOZ s4



Safety relay for monitoring E-STOP pushbuttons, safety gates and light beam devices

Approvals

PNOZ s4	
	◆
	◆
	◆

Unit features

- ▶ Positive-guided relay outputs:
 - 3 safety contacts (N/O), instantaneous
 - 1 auxiliary contact (N/C), instantaneous
- ▶ 1 semiconductor output
- ▶ Connection options for:
 - E-STOP pushbutton
 - Safety gate limit switch
 - Reset button
 - Light barriers
 - PSEN
- ▶ A connector can be used to connect 1 PNOZsigma contact expander module
- ▶ Operating modes can be set via rotary switch
- ▶ LED indicator for:
 - Supply voltage
 - Input status, channel 1
 - Input status, channel 2
 - Switch status, safety contacts
 - Reset circuit
 - Error
- ▶ Plug-in connection terminals (either spring-loaded terminal or screw terminal)

Unit description

The safety relay meets the requirements of EN 60947-5-1, EN 60204-1 and VDE 0113-1 and may be used in applications with

- ▶ E-STOP pushbuttons
- ▶ Safety gates
- ▶ Light beam devices

Safety features

The relay meets the following safety requirements:

- ▶ The circuit is redundant with built-in self-monitoring.
- ▶ The safety function remains effective in the case of a component failure.
- ▶ The correct opening and closing of the safety function relays is tested automatically in each on-off cycle.
- ▶ The unit has an electronic fuse.

Block diagram

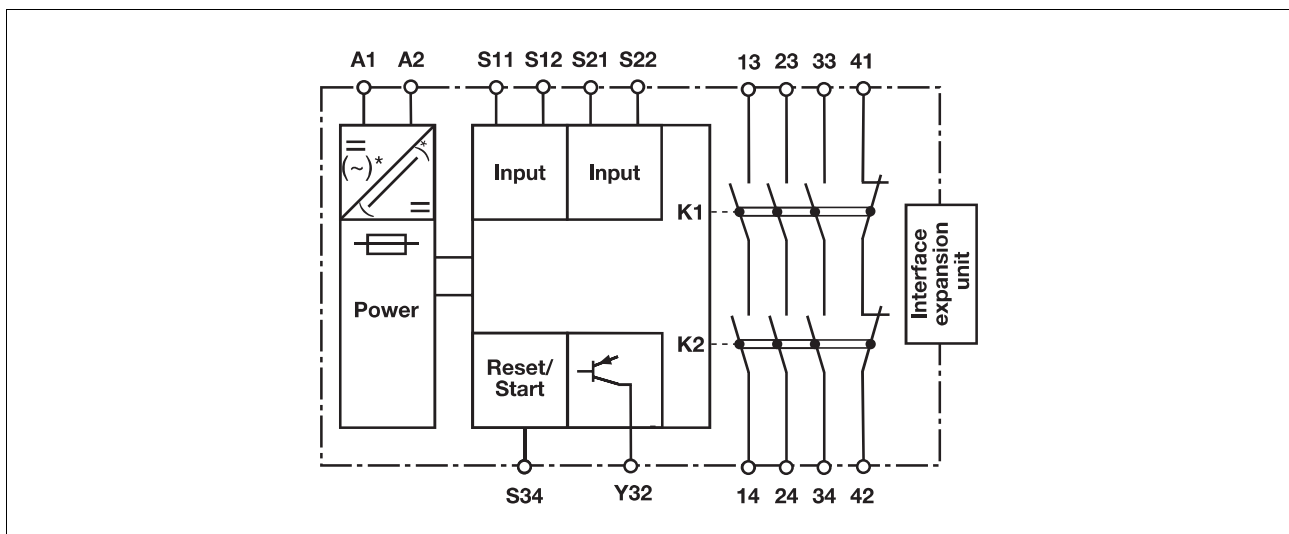

* only when $U_B = 48 - 240 \text{ VAC/DC}$

Up to PL e of EN ISO 13849-1 PNOZ s4

Function description

- ▶ Single-channel operation: no redundancy in the input circuit, earth faults in the reset and input circuit are detected.
- ▶ Dual-channel operation without detection of shorts across contacts: redundant input circuit, detects
 - earth faults in the reset and input circuit,
 - short circuits in the input circuit and, with a monitored reset, in the reset circuit too.
- ▶ Dual-channel operation with detection of shorts across contacts: redundant input circuit, detects
 - earth faults in the reset and input

- short circuits in the input circuit and, with a monitored reset, in the reset circuit too,
- shorts between contacts in the input circuit.
- ▶ Automatic start: Unit is active once the input circuit has been closed.
- ▶ Manual reset: Unit is active once the input circuit is closed and then the reset circuit is closed.
- ▶ Monitored reset with falling edge: Unit is active once
 - the input circuit is closed and then the reset circuit is closed and opened again.
 - the reset circuit is closed and then opened again once the in-

- put circuit is closed.
- ▶ Monitored reset with rising edge: Unit is active once the input circuit is closed and once the reset circuit is closed after the waiting period has elapsed (see technical details).
- ▶ Reset with start-up test: The unit checks whether safety gates that are closed are opened and then closed again when supply voltage is applied.
- ▶ Increase in the number of available instantaneous safety contacts by connecting contact expander modules or external contactors/relays; A connector can be used to connect 1 PNOZsigma contact expander module.

Timing diagram

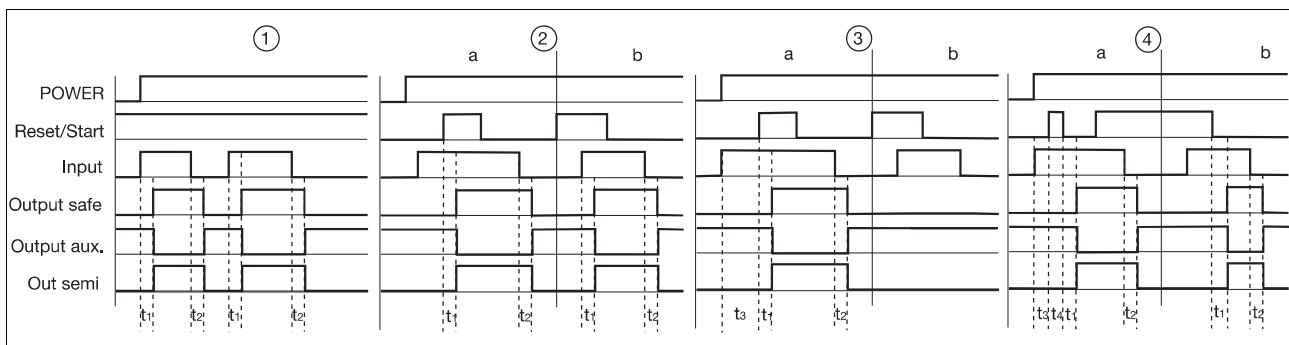

Key

- ▶ Power: Supply voltage
- ▶ Reset/start: Reset circuit S34 S34
- ▶ Input: Input circuits S11-S12, S21-S22
- ▶ Output safe: Safety contacts 13-14, 23-24, 33-34
- ▶ Output aux.: Auxiliary contacts 41-42
- ▶ Out semi: Semiconductor output Y32
- ▶ ①: Automatic reset
- ▶ ②: Manual reset
- ▶ ③: Monitored reset with rising edge
- ▶ ④: Monitored reset with falling edge
- ▶ a: Input circuit closes before reset circuit
- ▶ b: Reset circuit closes before input circuit
- ▶ t₁: Switch-on delay
- ▶ t₂: Delay-on de-energisation
- ▶ t₃: Waiting period
- ▶ t₄: Waiting period reset circuit was closed

Wiring

Please note:

- ▶ Information given in the “Technical details” must be followed.
- ▶ Outputs 13-14, 23-24, 33-34 are safety contacts, output 41-42 is an auxiliary contact (e.g. for display).
- ▶ To prevent contact welding, a fuse should be connected before the output contacts (see technical details).
- ▶ Calculation of the max. cable runs I_{max} in the input circuit:

$$I_{max} = \frac{R_{lmax}}{R_l / km}$$

R_{lmax} = max. overall cable resistance (see technical details)
 R_l / km = cable resistance/km

- ▶ Use copper wire that can withstand 60/75 °C.
- ▶ Sufficient fuse protection must be provided on all output contacts with capacitive and inductive loads.

Up to PL e of EN ISO 13849-1 PNOZ s4

Preparing for operation

► Supply voltage

Supply voltage	AC	DC

► Input circuit

Input circuit	Single-channel	Dual-channel
E-STOP without detection of shorts across contacts		
E-STOP with detection of shorts across contacts		
Safety gate without detection of shorts across contacts		
Safety gate with detection of shorts across contacts		
Light beam device or safety switch with detection of shorts across contacts via ESPE (only when $U_B = 24\text{ VDC}$)		

Up to PL e of EN ISO 13849-1 PNOZ s4

▶ Reset circuit/feedback loop

Reset circuit/feedback loop	Reset circuit	Feedback circuit
Automatic reset		
Manual/monitored reset		

▶ Semiconductor output

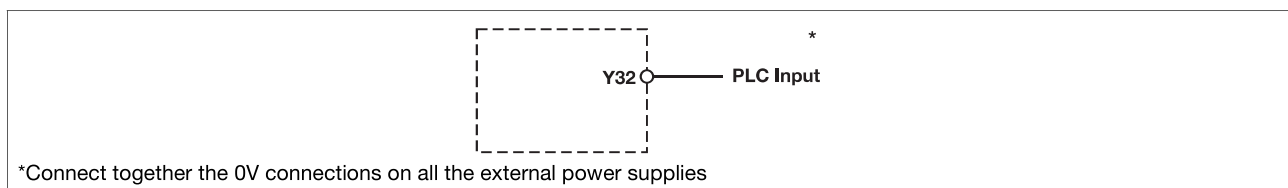

▶ Key

S1/S2	E-STOP/safety gate switch
S3	Reset button
	Switch operated
	Gate open
	Gate closed

Up to PL e of EN ISO 13849-1 PNOZ s4

Terminal configuration

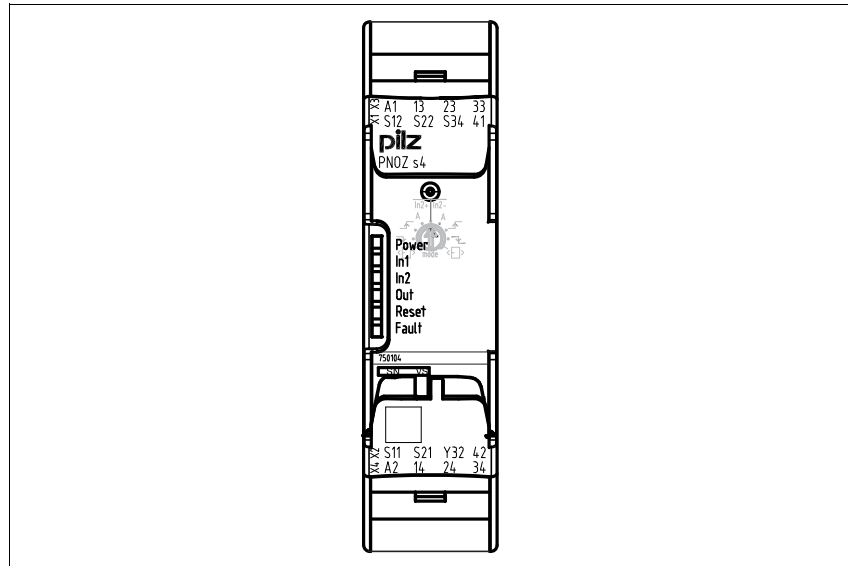

Installation

Install base unit without contact expander module:

- ▶ Ensure that the plug terminator is inserted at the side of the unit.

Connect base unit and PNOZsigma contact expander module:

- ▶ Remove the plug terminator at the side of the base unit and at the contact expander module.
- ▶ Connect the base unit and the contact expander module to the supplied connector before mounting the units to the DIN rail.

Installation in control cabinet

- ▶ The safety relay should be installed in a control cabinet with a protection type of at least IP54.
- ▶ Use the notch on the rear of the unit to attach it to a DIN rail (35 mm).
- ▶ When installed vertically: Secure the unit by using a fixing element (e.g. retaining bracket or end angle).
- ▶ Push the unit upwards or downwards before lifting it from the DIN rail.

Dimensions

*with spring-loaded terminals

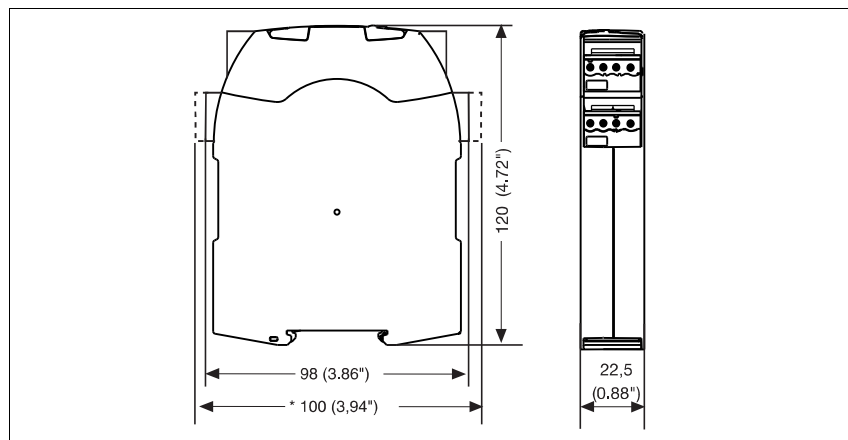

Up to PL e of EN ISO 13849-1 PNOZ s4

Notice

This data sheet is only intended for use during configuration. For installation and operation, please refer to the operating instructions supplied with the unit.

Service life graph

The service life graphs indicate the number of cycles from which failures due to wear must be expected. The wear is mainly caused by the electrical load; the mechanical load is negligible.

U_B 24 VDC

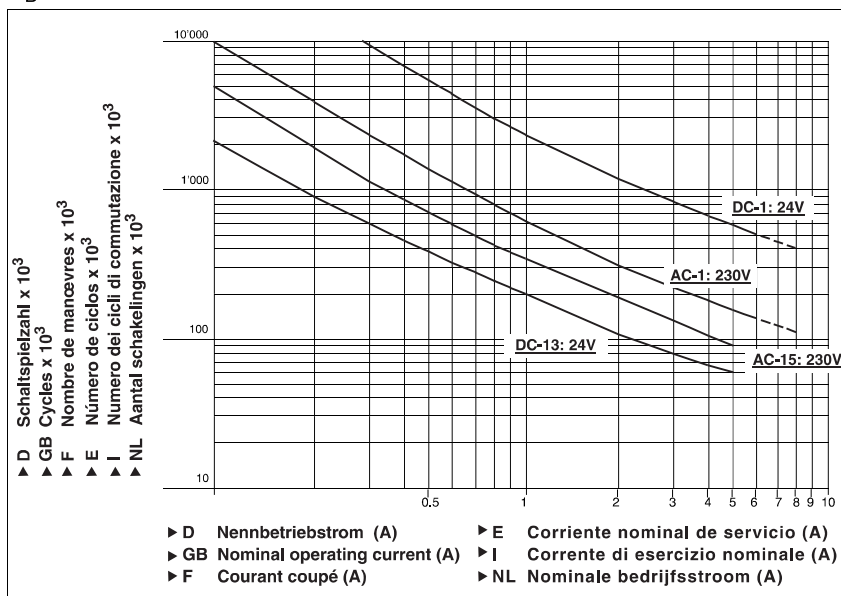

Example

- ▶ Inductive load: 0.2 A
- ▶ Utilisation category: AC15
- ▶ Contact service life: 4,000,000 cycles

Provided the application requires fewer than 4,000,000 cycles, the PFH value (see technical details) can be used in the calculation.

To increase the service life, sufficient spark suppression must be provided on all output contacts. With capacitive loads, any power surges that occur must be noted. With contactors, use freewheel diodes for spark suppression.

We recommend you use semiconductor outputs to switch 24 VDC loads.

Up to PL e of EN ISO 13849-1 PNOZ s4

U_B 48-240 VAC/DC

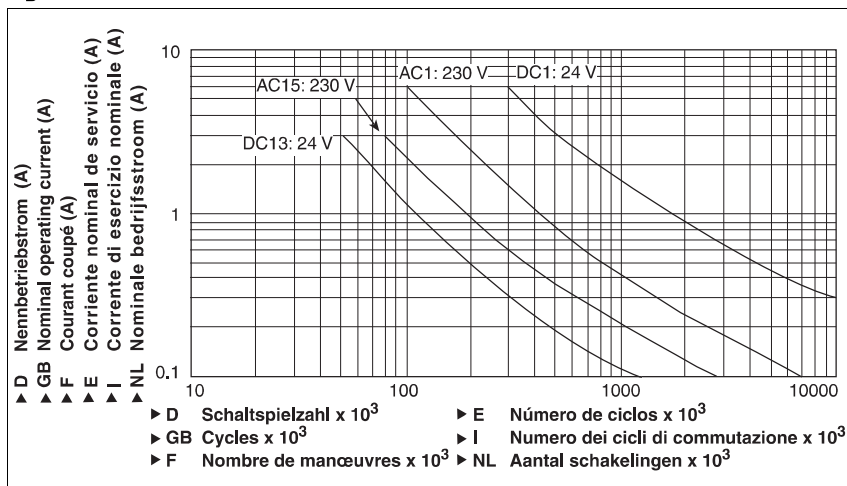

Example

- ▶ Inductive load: 0.2 A
- ▶ Utilisation category: AC15
- ▶ Contact service life: 1 000 000 cycles

Provided the application requires fewer than 1 000 000 cycles, the PFH value (see technical details) can be used in the calculation.

To increase the service life, sufficient spark suppression must be provided on all output contacts. With capacitive loads, any power surges that occur must be noted. With contactors, use freewheel diodes for spark suppression.

We recommend you use semiconductor outputs to switch 24 VDC loads.

Technical details

Electrical data

Supply voltage	
Supply voltage U _B DC	24 V
Supply voltage U _B AC/DC	48 - 240 V
Voltage tolerance	-15 %/+10 %
Power consumption at U _B AC	5.0 VA No. 750134, 751134
Power consumption at U _B DC	2.5 W
Frequency range AC	50 - 60 Hz
Residual ripple DC	20 %, 160 %
Voltage and current at	
Input circuit DC: 24.0 V	50.0 mA
Reset circuit DC: 24.0 V	50.0 mA
Feedback loop DC: 24.0 V	50.0 mA
Number of output contacts	
Safety contacts (S) instantaneous:	3
Auxiliary contacts (N/C):	1

Up to PL e of EN ISO 13849-1 PNOZ s4

Electrical data	
Utilisation category in accordance with EN 60947-4-1	
Safety contacts: AC1 at 240 V	I_{\min} : 0.01 A , I_{\max} : 6.0 A P_{\max} : 1500 VA
Safety contacts: DC1 at 24 V	I_{\min} : 0.01 A , I_{\max} : 6.0 A P_{\max} : 150 W
Auxiliary contacts: AC1 at 240 V	I_{\min} : 0.01 A , I_{\max} : 6.0 A P_{\max} : 1500 VA
Auxiliary contacts: DC1 at 24 V	I_{\min} : 0.01 A , I_{\max} : 6.0 A P_{\max} : 150 W
Utilisation category in accordance with EN 60947-5-1	
Safety contacts: AC15 at 230 V	I_{\max} : 3.0 A No. 750134, 751134 5.0 A No. 750104, 751104
Safety contacts: DC13 at 24 V (6 cycles/min)	I_{\max} : 4.0 A No. 750134, 751134 5.0 A No. 750104, 751104
Auxiliary contacts: AC15 at 230 V	I_{\max} : 3.0 A No. 750134, 751134 5.0 A No. 750104, 751104
Auxiliary contacts: DC13 at 24 V (6 cycles/min)	I_{\max} : 4.0 A No. 750134, 751134 5.0 A No. 750104, 751104
Contact material	AgCuNi + 0.2 µm Au
External contact fuse protection ($I_k = 1$ kA) to EN 60947-5-1	
Blow-out fuse, quick	
Safety contacts:	10 A No. 750104, 751104 6 A No. 750134, 751134
Auxiliary contacts:	10 A No. 750104, 751104 6 A No. 750134, 751134
Blow-out fuse, slow	
Safety contacts:	4 A No. 750134, 751134 6 A No. 750104, 751104
Auxiliary contacts:	4 A No. 750134, 751134 6 A No. 750104, 751104
Circuit breaker 24 VAC/DC, characteristic B/C	
Safety contacts:	4 A No. 750134, 751134 6 A No. 750104, 751104
Auxiliary contacts:	4 A No. 750134, 751134 6 A No. 750104, 751104
Semiconductor outputs (short circuit proof)	24.0 V DC, 20 mA
Max. overall cable resistance $R_{l\max}$ input circuits, reset circuits	
single-channel at U_B DC	30 Ohm
single-channel at U_B AC	30 Ohm No. 750134, 751134
dual-channel without detect. of shorts across contacts at U_B DC	30 Ohm No. 750134, 751134 60 Ohm No. 750104, 751104
dual-channel without detect. of shorts across contacts at U_B AC	30 Ohm No. 750134, 751134
dual-channel with detect. of shorts across contacts at U_B DC	30 Ohm
dual-channel with detect. of shorts across contacts at U_B AC	30 Ohm No. 750134, 751134
Min. input resistance in the starting torque	110 Ohm
Safety-related characteristic data	
PL in accordance with EN ISO 13849-1: 2006	PL e (Cat. 4)
Category in accordance with EN 954-1	Cat. 4
SIL CL in accordance with EN IEC 62061	SIL CL 3
PFH in accordance with EN IEC 62061	2.31E-09
SIL in accordance with IEC 61511	SIL 3
PFD in accordance with IEC 61511	2.03E-06
t_M in years	20

Up to PL e of EN ISO 13849-1 PNOZ s4

Times	
Switch-on delay	
with automatic reset typ.	170 ms
with automatic reset max.	300 ms
with automatic reset after power on typ.	350 ms
with automatic reset after power on max.	600 ms
with manual reset typ.	40 ms
on monitored reset with rising edge typ.	35 ms
on monitored reset with rising edge max.	50 ms
on monitored reset with falling edge typ.	55 ms
on monitored reset with falling edge max.	70 ms
Delay-on de-energisation	
with E-STOP typ.	10 ms
with E-STOP max.	20 ms
with power failure typ.	40 ms
with power failure max.	80 ms
Recovery time at max. switching frequency 1/s after E-STOP	100 ms No. 750104, 751104 50 ms No. 750134, 751134
after power failure	100 ms
Waiting period with a monitored reset	
with rising edge	120 ms
with falling edge	150 ms No. 750134, 751134 250 ms No. 750104, 751104
Min. start pulse duration with a monitored reset	
with rising edge	30 ms
with falling edge	100 ms
Simultaneity, channel 1 and 2	∞
Supply interruption before de-energisation	20 ms
Environmental data	
EMC	EN 60947-5-1, EN 61000-6-2, EN 61000-6-4
Vibration to EN 60068-2-6	
Frequency	10 - 55 Hz
Amplitude	0.35 mm
Climatic suitability	EN 60068-2-78
Airgap creepage in accordance with EN 60947-1	
Pollution degree	2
Overtoltage category	III
Rated insulation voltage	250 V
Rated impulse withstand voltage	4.00 kV
Ambient temperature	-10 - 55 °C
Storage temperature	-40 - 85 °C
Protection type	
Mounting (e.g. cabinet)	IP54
Housing	IP40
Terminals	IP20
Mechanical data	
Housing material	
Housing	PC
Front	PC
Cross section of external conductors with screw terminals	
1 core flexible	0.25 - 2.50 mm², 24 - 12 AWG No. 750104, 750134
2 core, same cross section, flexible:	
with crimp connectors, without insulating sleeve	0.25 - 1.00 mm², 24 - 16 AWG No. 750104, 750134
without crimp connectors or with TWIN crimp connectors	0.20 - 1.50 mm², 24 - 16 AWG No. 750104, 750134
Torque setting with screw terminals	0.50 Nm No. 750104, 750134
Cross section of external conductors with spring-loaded terminals: Flexible with/without crimp connectors	0.20 - 2.50 mm², 24 - 12 AWG No. 751104, 751134

Up to PL e of EN ISO 13849-1 PNOZ s4

Mechanical data	
Spring-loaded terminals: Terminal points per connection	2 No. 751104, 751134
Stripping length	9 mm No. 751104, 751134
Dimensions	
Height	102.0 mm No. 751104, 751134 96.0 mm No. 750104, 750134
Width	22.5 mm
Depth	120.0 mm
Weight	
	190 g No. 750104, 751104 210 g No. 750134, 751134

No. stands for order number.

It is essential to consider the relay's service life graphs. The relay outputs' safety-related characteristic data is only valid if the values in the service life graphs are met.

The PFH value depends on the switching frequency and the load on the relay output.
If the service life graphs are not accessible, the stated PFH value can be

used irrespective of the switching frequency and the load, as the PFH value already considers the relay's B10d value as well as the failure rates of the other components.

All the units used within a safety function must be considered when calculating the safety characteristic data.

The standards current on **2006-04** apply.

Conventional thermal current		
Number of contacts	I_{th} (A) at U_B DC	I_{th} (A) at U_B AC
1	6.00 A	6.00 A No. 750134, 751134
2	6.00 A	6.00 A No. 750134, 751134
3	4.50 A No. 750134, 751134 5.00 A No. 750104, 751104	4.50 A No. 750134, 751134

Order reference			
Type	Features	Terminals	Order no.
PNOZ s4	24 VDC	With screw terminals	750 104
PNOZ s4 C	24 VDC	With spring-loaded terminals	751 104
PNOZ s4	48 – 240 VAC/DC	With screw terminals	750 134
PNOZ s4 C	48 – 240 VAC/DC	With spring-loaded terminals	751 134