

BENDING BEAM: capacity from 75 kg to 300 kg

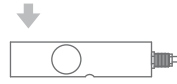

IP67



SHEAR BEAM: capacity from 500 kg to 5000 kg



IP68

- AISI 4340 NICKEL PLATED STEEL
- COMBINED ERROR $\leq \pm 0.02\%$
- PROTECTION CLASS IP67 - IP68

MOUNTING KITS

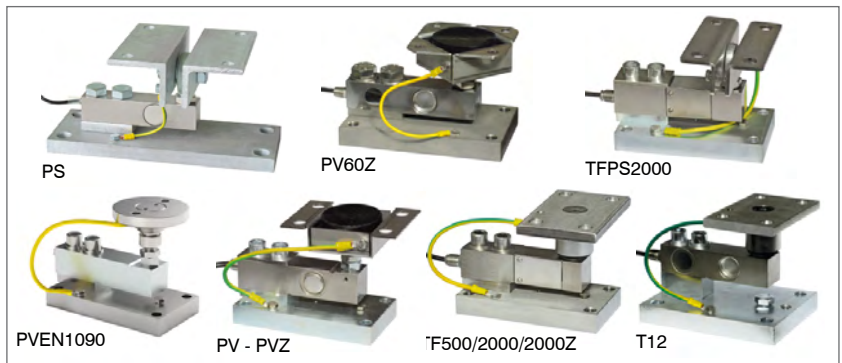

CAPACITY	kg	ACCURACY CLASS C3		NET WEIGHT (kg)	CODE
75		-	-	1	FTK75
150		-	-	1	FTK150
300		-	-	1	FTK300
500		-	-	1	FTK500
1000		•	•	1.1	FTK1000
2000		•	•	1.1	FTK2000
3000		•	•	1.1	FTK3000
5000		•	•	1.1	FTK5000

CERTIFICATIONS



OIML R60 C3



Complies with the Eurasian Customs Union standards



Equivalent of the CE marking for the United Kingdom



Complies with United Kingdom regulations for legal for trade use

CERTIFICATIONS ON REQUEST



ATEX II 1GD (zone 0-1-2-20-21-22) (CE - UKCA)



IECEx (zone 0-1-2-20-21-22)



Complies with the Eurasian Customs Union standards for use in potentially explosive atmospheres

DIMENSIONS (mm)

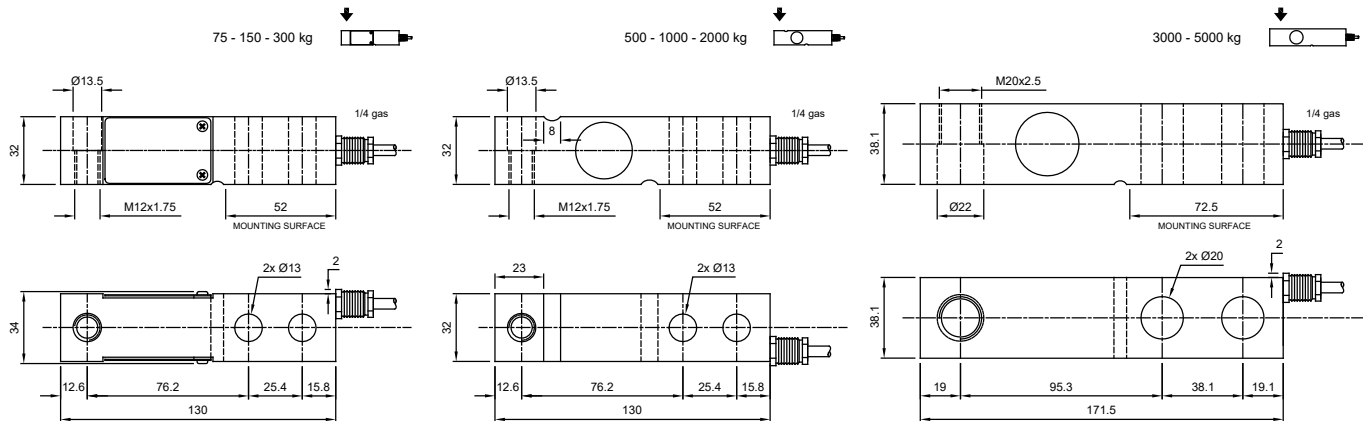

For the load cell fixing screws, provide the tightening torque indicated in the table

Screw	M12		M20	
	Screw class	6.8	8.8	6.8
Tightening torque	50 Nm	79 Nm	290 Nm	400 Nm

TECHNICAL FEATURES

Material	AISI 4340 nickel plated steel		
OIML R60 Accuracy class • Verification intervals	-		C3 • 3000
Nominal load (E max)	75 - 150 - 300 - 500 kg		1000 - 2000 - 3000 - 5000 kg
Minimum verification interval (V min)	-		E max / 12000
Combined error	≤ ±0.02%		
Protection class	IP67 (75 - 300 kg), IP68 (500 - 5000 kg)		
Rated output	2 mV/V ±0.1%	Input resistance	400 Ω ±10
Temperature effect on zero	0.002% °C	Output resistance	352 Ω ±2
Temperature effect on span	0.0012% °C	Zero balance	±2%
Compensated temperature range	-10 °C / +40 °C	Insulation resistance	≥5000 MΩ
Operating temperature range	-20 °C / +70 °C	Safe overload (% of full scale)	150%
Creep at nominal load in 30 minutes	0.03%	Ultimate overload (% of full scale)	250%
Max supply voltage without damage	15 V	Deflection at nominal load	0.6 mm

ELECTRICAL CONNECTIONS

Cable length	6 m
Cable diameter	5 mm
Cores	6 x 0.24 mm ²

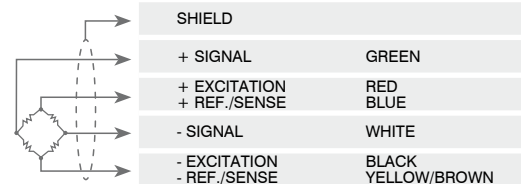

COMPLEMENTARY ACCESSORIES

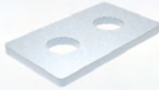
DESCRIPTION	CODE
 <p>Special steel block for capacities up to 2000 kg.</p>	PIASTRINO

The Company reserves the right to make changes to the technical data, drawings and images without notice.