

Part number

CHP 10 LS



Surface mounting housing, C-TYPE series, with 1 lever, Pg16 cable entry, size "57.27", with metal cover

Product description

| | |
|----------------------|--------------------------|
| Product type | Surface mounting housing |
| Series | C-TYPE |
| Closing type | With 1 lever |
| Size | Size "57.27" |
| Cable entry | With cable entry Pg16 |
| Specification | With metal cover |

Technical data

IP degree of protection IP65 / IP66 / IP69

Further technical details

| | |
|---|----------------|
| Weight | 300,00 g |
| Operating temperature range (min, max) | -40°C...+125°C |

Material properties

| | |
|------------------------------|---------------|
| Colour | RAL 7040 grey |
| RoHs conformity | Compliant |
| China RoHs - EFUP | E |
| REACH SVHC substances | No |

Approvals / Standards

| | |
|-----------------------|---------|
| Certifications | DNV, BV |
| UL | ECBT2 |
| cUL | ECBT8 |

General ordering information

EAN13 code 8015747021890

Packaging Information

| | |
|----------------------------------|-----------------------|
| Packaging length | 475,00 mm |
| Packaging height | 170,00 mm |
| Packaging width | 150,00 mm |
| Packaging weight | 3,11 kg |
| Packaging volume | 12,11 dm ³ |
| Packaging description | Carton box |
| Packaging quantity | 10 Pcs |
| Packaging EAN code | 8015747021906 |
| Sub-packaging weight | 1,56 kg |
| Sub-packaging description | Plastic packaging |
| Sub-packaging quantity | 5 Pcs |
| Sub-packaging EAN barcode | 8015747021913 |

Part number

CHP 10 LS



Catalogue drawings

CHP L - CAP L MHP L - MAP L

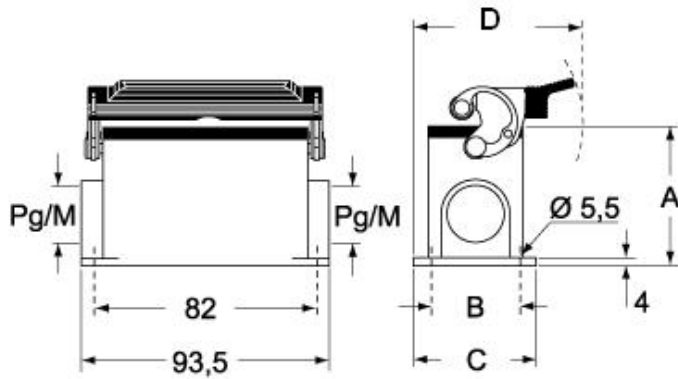

CHP LS - CAP LS MHP LS - MAP LS

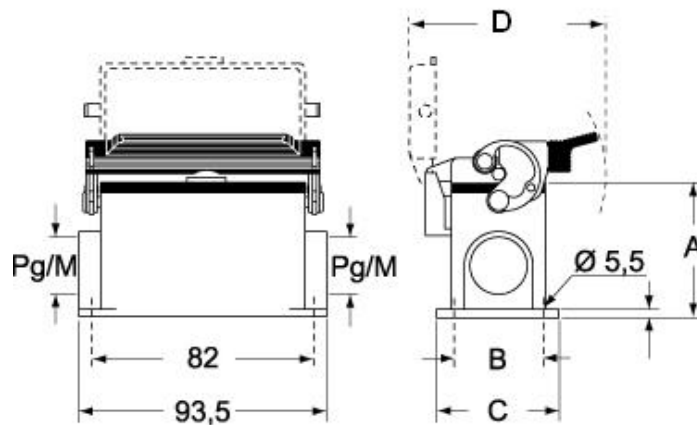

Notes

Dimensions shown in mm are not binding and may be changed without notice.